

PRODUCT HANDBOOK

FORD MOLDBOARD PLOWS

- PART I -



Tractor and Implement Division
FORD MOTOR COMPANY
Birmingham Michigan

www.ntractorclub.com

REMEMBER —

WHEN YOU SELL

Ford Moldboard Plows:

- Read this Manual
- Plan your sale and your approach
 - Know prospect's needs
 - Stress benefits to him
 - Stress flexibility, performance and convenience
- Prove your conversation by demonstration



Make sure your prospect clearly understands all of the benefits that Ford Moldboard Plows will bring him.



Make sure he appreciates the superior features of the Ford Moldboard Plows. Show him these features and the built-in quality.



Demonstrate the recommended procedures for getting proper plow performance.

TRACTOR AND IMPLEMENT DIVISION
FORD MOTOR COMPANY
BIRMINGHAM **MICHIGAN**

More Sales Power for YOU!



Here's an easy way to help you sell more by using the tremendous merchandising advantages the flexibility in the Ford Moldboard Plow line offers.

Look over the illustrations and descriptive material on the following pages. Get the information firmly in mind. It will help you give your customers what they want—what is best for their individual plowing needs.

If you plan to use this manual and the silent slidefilm "Ford Moldboard Plows—Part I" for acquainting others with this important merchandising story, then assure yourself of doing a good job by:

1. Going through the film several times to get the over-all view of its content.
2. Read the information accompanying each frame picture so you will know what is to be pointed out and discussed.
3. Take your time in showing and talking about each frame as it is projected on the screen.
4. Stand to the viewer's left of the screen and use a suitable pointer to locate information points on the screen.
5. Give the audience opportunity to ask questions before going on to the next frame.
6. Use actual plows and plow parts for a follow-up discussion with the group, after showing the film, such as:
 - a. Stubble and dual purpose frog.
 - b. Regular and short share.
 - c. Shot blast and polished share.
 - d. 3-bottom 14" plow, assembled.
 - e. F.M.D. cross shaft.
 - f. Standard bottom for sample.
7. Also use the questions provided on the back pages of this booklet as an aid in reviewing information presented with the film.
8. Use sales aids such as advertising literature, sales manual and especially the plow wheel card "Ford Plow Selector," SP-6528-2, as a basis for further discussion.
9. Stress the retail merchandising benefits to the salesman, of understanding, talking, and demonstrating the outstanding flexibility to meet customers' plowing needs, of the Ford line of moldboard plows.

KNOW MORE — SELL MORE

SLIDEFILM – FORD MOLDBOARD PLOWS – PART I

LEADER'S GUIDE

Every person who sells and services plows should be in a position to help farmers with their plowing problems. There is one positive way to be able to do this: Know your Ford line, understand how each plow bottom and each accessory performs under varying conditions.

Knowing the Ford plow line and conditions in your area, will put you in a position to sell a farmer the plow best suited for his land and to give him effective help when he encounters plowing problems.

We have a slidefilm which will help us gain the basic information essential to effectively selling and servicing the Ford line of moldboard plows. Let's look at the film.

LIGHTS OUT—FILM ON

FORD MOLDBOARD PLOWS PART I

First let's consider some of the more important reasons as to . . .

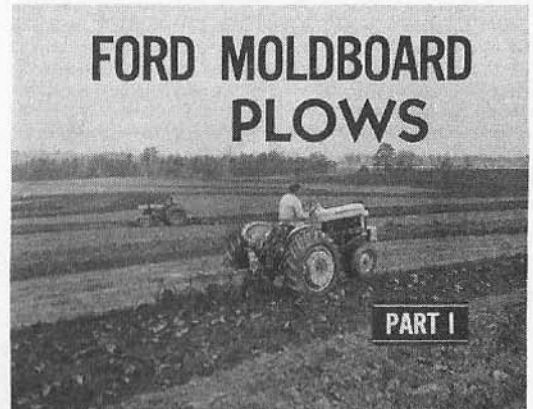

WHY WE PLOW

1. Pulverize the soil before planting.
2. Work vegetation and manure into the soil.
3. Provide soil aeration.
4. Destroy weeds.
5. Help the soil absorb precipitation.
6. Destroy insects, their eggs, larvae and breeding places.
7. Produce a surface resistant to wind and water erosion.

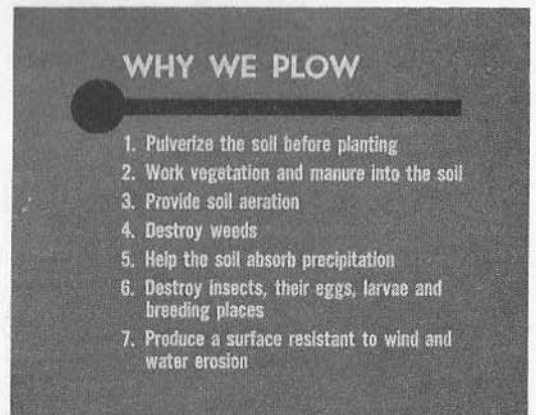

2

Next, we should understand . . . www.ntractorclub.com

THE IMPORTANCE OF GOOD PLOWING

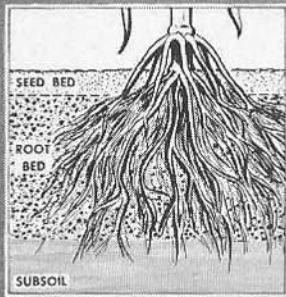

3

Ordinarily, all stubble, weeds and plant residues should be turned under and mixed with the soil to provide a good seedbed and rootbed. Corn borer control, particularly, requires good coverage of corn stalks and pulverization of the soil.

To get a good seedbed and rootbed, there are several . . .

THE IMPORTANCE OF GOOD PLOWING to good seedbed and rootbed preparation. "Seedbed" refers to the top inch or two of soil where the planted seeds germinate. "Rootbed" refers to the lower layer of plowed soil where plant roots feed. In addition to making it possible to work up a good seedbed, good plowing produces a firm, well granulated rootbed.

KEY FACTORS IN GOOD PLOWING

1. Plowing when soil conditions are right
2. Size and type of bottoms used
3. Relation between depth of plowing and width of cut
4. Keeping plow bottom in normal position in relation to furrow slice
5. Proper care and adjustment of plow
6. Trash coverage
7. Plowing speed

4

KEY FACTORS IN GOOD PLOWING to be considered:

1. Plowing when soil conditions are right.
2. Size and type of bottoms used.
3. Relation between depth of plowing and width of cut.
4. Keeping plow bottom in normal position in relation to furrow slice.
5. Proper care and adjustment of plow.
6. Trash coverage.
7. Plowing speed.

Let's discuss each of these key factors.

1. PLOWING WHEN SOIL CONDITIONS ARE RIGHT

To get a good uniform seedbed, avoid plowing in extremes of wet, or dry, hard soil whenever possible.

2. THE SIZE AND TYPE OF BOTTOMS USED

Different soil types require different bottoms. Sand vs. clay, sod vs. stubble, etc. Use the size and type of bottom which performs best in the type of soil to be plowed.

3. RELATIONSHIP BETWEEN DEPTH OF PLOWING AND WIDTH OF CUT

A plow is usually designed to work best at a depth of from 50 to 60 per cent of its width of cut—under normal speed and plowing conditions.

4

4. **KEEPING PLOW IN NORMAL POSITION IN RELATION TO FURROW SLICE**
A plow bottom is designed to operate in a definite position relative to the forces exerted by furrow slice. Improper plow adjustment not only affects the quality of the plowing job, but can cause severe side draft, excessive wear on shares and moldboards, and generally mean a waste of power and fuel.
5. **PROPER CARE AND ADJUSTMENT OF PLOW**
Regular lubrication of moving parts and maintaining good polish on moldboards is essential to good plowing. Adjustments should be checked carefully when different fields, soils or crop conditions are encountered. The same plow may require different adjustment between spring and fall plowing in the same field.
6. **TRASH COVERAGE**
For complete trash coverage, the right bottoms, a properly adjusted plow, the right attachments, and even the right plowing speed are all essential factors. Some trash conditions may even require special attention before plowing is practical.
7. **PLOWING SPEED**
Some bottoms are designed for faster plowing speeds, others must be operated more slowly to get specific results desired. A good understanding of the "action" of the various bottoms is essential to recommending the proper plow for the job, as well as for trouble shooting plowing problems.

Now let's review some of the more common . . .

TERMS USED IN PLOWING.

These terms include the . . .

Furrow wall, furrow bottom, furrow slice, furrow crown and furrow crease.

These are common terms we will be referring to frequently.

This brings us to the . . .

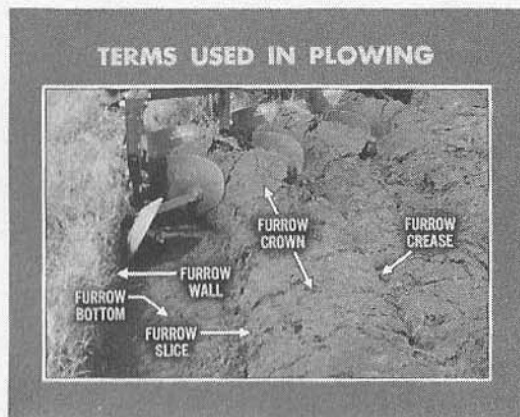

5

BASIC FUNCTIONS OF THE MOLDBOARD PLOW:

- Cuts or breaks loose furrow slice
- Lifts furrow slice
- Inverts furrow slice
- Pulverizes or granulates furrow slice and covers trash

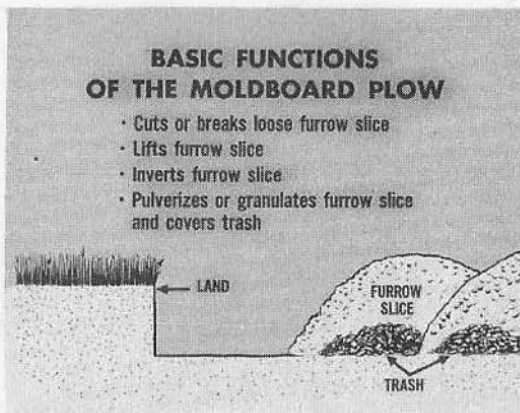

6

Another point of interest is the . . .

EFFECTS OF SOIL TYPE ON DRAFT (General Purpose Plow)

EFFECTS OF SOIL TYPE ON DRAFT (GENERAL PURPOSE PLOW)	
TYPE OF SOIL	APPROX. LBS. PER SQUARE INCH
SAND	4
SILT LOAM	6
LOAM	8
CLAY LOAM	9
CLAY	14
GUMBO OR ADOBE	20

7

Type of Soil	Approximate Pounds per Square Inch
Sand.....	4
Silt Loam.....	6
Loam.....	8
Clay Loam.....	9
Clay.....	14
Gumbo or Adobe.....	20

Soil type has a major effect on draft, the range being from 4 to 20 pounds per square inch of furrow slice. (Note: Square inches handled by each bottom is figured by multiplying width of cut by depth of furrow slice.) Other factors influencing draft are amount of soil moisture, the soil cover, adjustment of the plow and condition of shares, coulters and jointers.



8

Now let's look at the line of FORD MOLD-BOARD PLOWS and see what is available to handle plowing in your area.

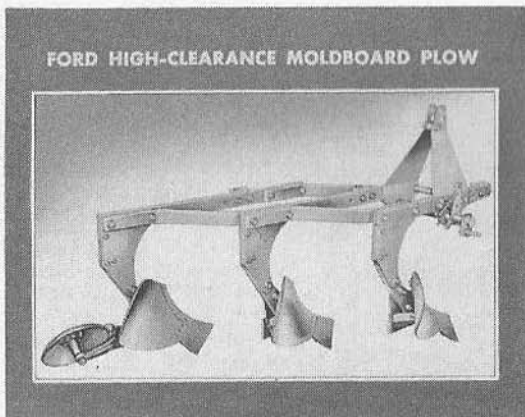

9

THE FORD HIGH CLEARANCE MOLD-BOARD PLOW features a strong, rigid truss frame construction, high beam clearance "break back" protection against damage along with maximum ease of adjustment.

THE FORD HIGH CLEARANCE MOLD-BOARD PLOW may be readily adapted FOR USE WITH THE FMD by simply installing an FMD cross shaft and adding a gauge wheel.

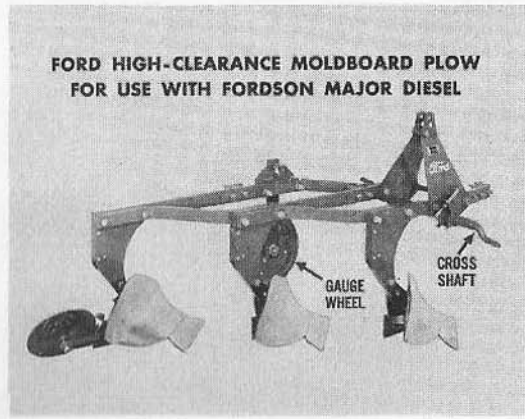

10

FORD HAS TWO LINES OF PLOW BOTTOMS

- The Economy Ford Bottom
- The Standard Ford Bottom

Note particularly, the difference in the shares on each bottom.

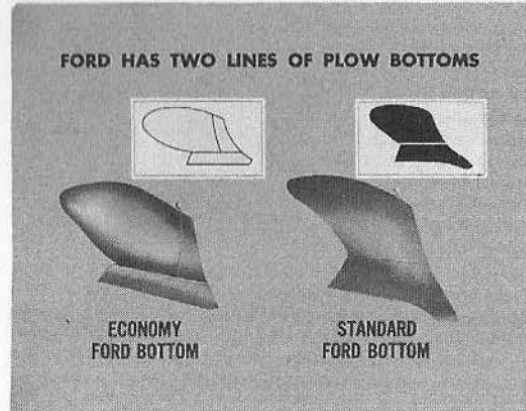

11

THERE ARE FOUR STANDARD BOTTOMS. ALL FOUR HAVE A ONE-PIECE MOLD-BOARD AND A CONVENTIONAL TYPE SHARE. They are the . . .

- Stubble
- General Purpose
- Sod and Clay, and
- Scotch bottom

Here are the . . .

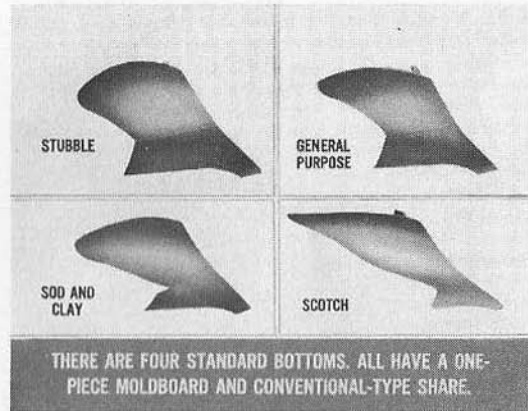

12

CHARACTERISTICS OF THE STANDARD STUBBLE BOTTOM

- Good trash coverage
- Good soil pulverization
- Good scouring
- Low speed

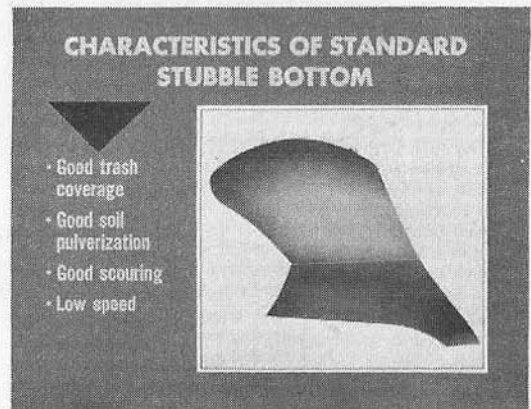

13

CHARACTERISTICS OF STANDARD GENERAL PURPOSE BOTTOM

- Designed to meet average plowing conditions
- High speed
- Light draft

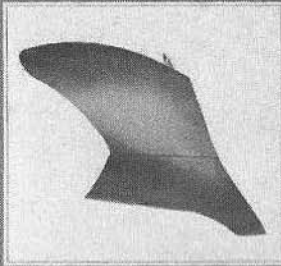

14

CHARACTERISTICS OF STANDARD GENERAL PURPOSE BOTTOM

- Designed to meet average plowing conditions
- High speed
- Light draft

CHARACTERISTICS OF STANDARD SOD AND CLAY BOTTOM

- Slow-turning moldboard prevents breaking furrow slice
- High speed gives flat effect
- Low speed gives crown effect

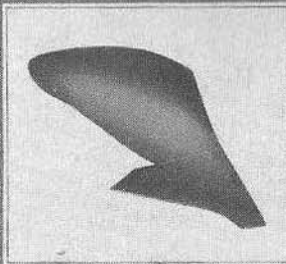

15

CHARACTERISTICS OF STANDARD SOD AND CLAY BOTTOM

- Slow turning moldboard prevents breaking furrow slice
- High speed gives flat effect
- Low speed gives crown effect

CHARACTERISTICS OF STANDARD SCOTCH BOTTOM

- Leaves right side of furrow strip fastened and stands slice on edge
- Admits air, provides water drainage for heavy soil
- Used on 10" and 12" plow frames

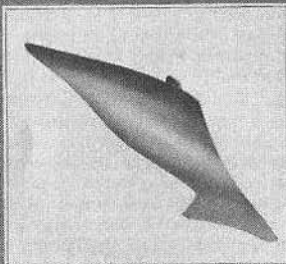

16

CHARACTERISTICS OF THE STANDARD SCOTCH BOTTOM

- Leaves right side of furrow strip fastened and stands slice on edge.
- Admits air, provides water drainage for heavy soil.
- Used on 10" and 12" plow frames.

So much for the Ford Standard Bottoms. Now we'll discuss the . . .

A LINE OF ECONOMY BOTTOMS

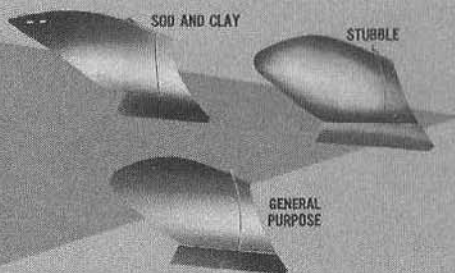

17

LINE OF ECONOMY BOTTOMS

There are three Ford Economy Bottoms

- Stubble
- General Purpose
- Sod and Clay

The basic performance characteristics of these three bottoms are practically the same as their counterparts we've just seen in the standard line.

FORD ECONOMY BOTTOMS

These bottoms are made up from the five basic parts you see here: Moldboard, Shin, Frog, Landside and Share.

- Shins are replaceable at 1/5 cost of entire moldboard.
- Razor blade shares are replaceable at a fraction of the cost of conventional shares.

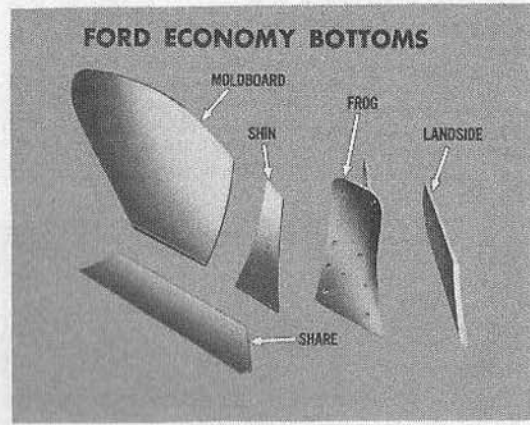

18

Here we see THE COMPLETE FORD ECONOMY BOTTOM.

Now let's consider some of the sales and service advantages of the . . .

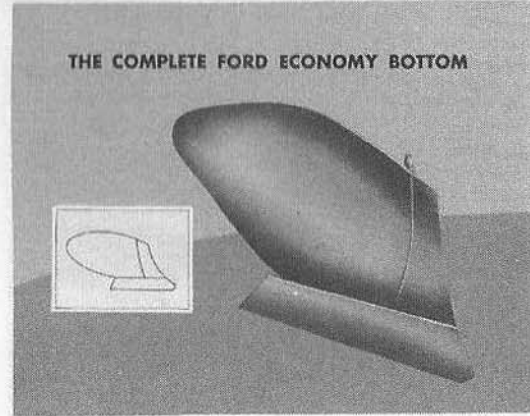

19

FORD ECONOMY PLOW BOTTOMS

- With these FORD ECONOMY PLOW BOTTOM parts: the two frogs, the shin, the landsides, the moldboards and shares, you can service many different Economy Bottoms.
- You can fill customer needs from a small inventory.
- You can work out and meet special plowing conditions and problems.

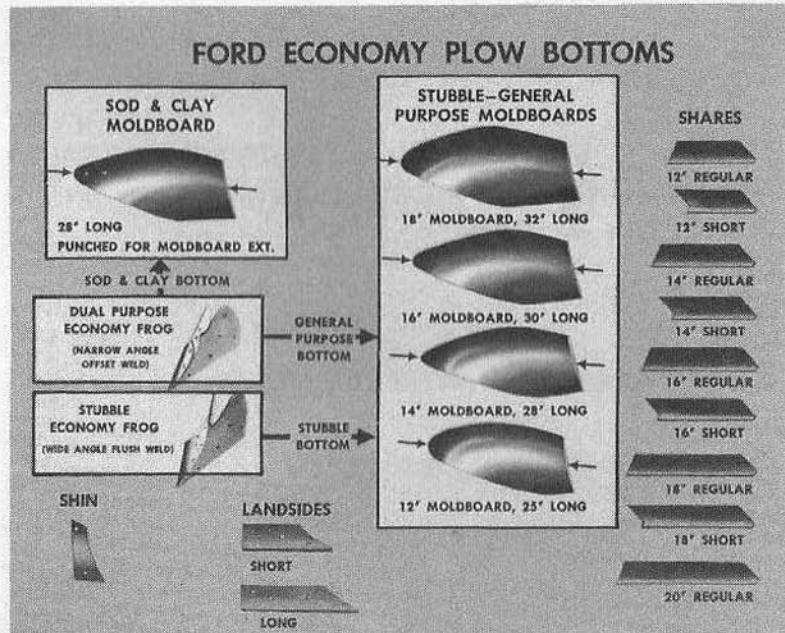

20

The first step in understanding the Ford line of Economy Plow Bottoms is to learn exactly what these parts are and the part they play in the selection and performance of Ford Economy Plows.

We'll start with the two frogs.

FROGS EASILY IDENTIFIED BY WELDS

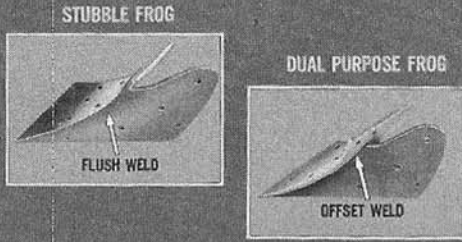

21

FROGS ARE EASILY IDENTIFIED BY WELDS

The Stubble Frog has a flush weld. The Dual Purpose Frog has an offset weld. Positive identification of the stubble or dual purpose frog can readily be made by checking the weld as to being flush or offset.

THE FROG GIVES THE PLOW BOTTOM ITS WEDGE SHAPE

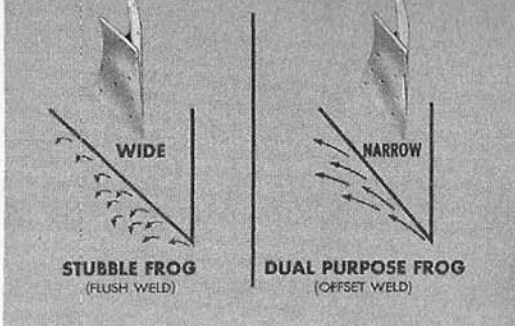

22

THE FROG GIVES THE PLOW BOTTOM ITS WEDGE SHAPE which helps the bottom enter the soil much as a chisel enters wood. You can see here that the Stubble Frog (which has the flush weld) has a wider angle or wedge shape than does the Dual Purpose Frog (which has the offset weld).

Now, when a plow bottom wedges its way into the soil, pressure is built up between the moldboard and the furrow slice. The

amount of this pressure is largely determined by the angle of the wedge or frog.

So in this case, the wider angled Stubble Frog will build up a greater pressure than will the narrower angled Dual Purpose Frog.

The important point here is that the amount of pressure a bottom sets up has a marked effect on its performance. The wider angle frog provides a bottom that scours more easily, and turns the furrow slice more abruptly for better pulverizing.

Any questions?

ECONOMY FROGS ARE DESIGNED SO SHARE POINTS WILL RUN SLIGHTLY BELOW SHARE WING

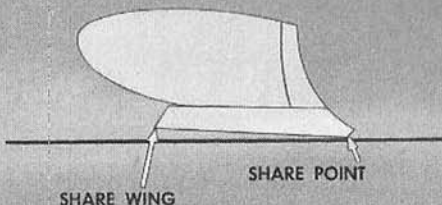

23

ECONOMY FROGS ARE DESIGNED SO SHARE POINTS WILL RUN SLIGHTLY BELOW THE SHARE WING when the bottom is operating level. This forward pitch of the share aids penetration.

DUAL PURPOSE FROG HAS GREATER FORWARD PITCH—MAKES UP A BETTER PENETRATING BOTTOM

On a bottom made up with the Dual Purpose Frog, the point of the share runs farther below the wing of the share than is the case with the Stubble Frog. Thus, the Dual Purpose Frog provides a better penetrating bottom. This illustration has been exaggerated to show the principle clearly. It should be pointed out here that the position of the landside (shaded area) on either frog is the same.

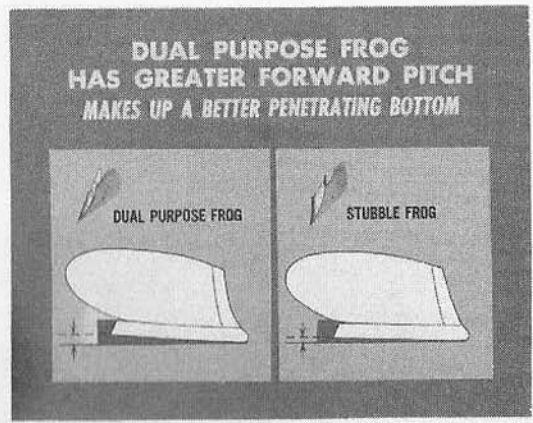

24

ONE SHIN FITS BOTH FROGS.

The same shin fits on either the Dual Purpose or Stubble Economy Frog, and is therefore used with all Economy bottoms.

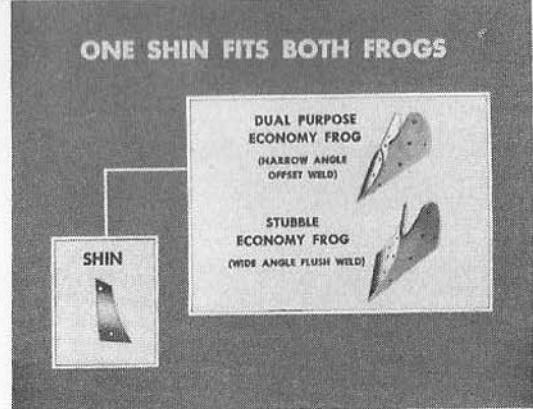

25

THE TWO LANDSIDES FIT BOTH FROGS

The short landside is used on all except rear bottoms.

The long landside is used on the rear bottom to accommodate the rolling landside. (Although it is not shown here, there is also the extra long landside with replaceable heel used on the 2 way 2 furrow plow and on the semi-mounted plows which do not have rolling landsides.)

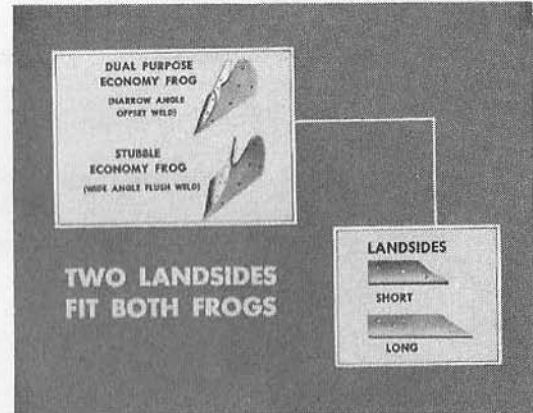

26

NINE SHARES FIT BOTH FROGS

These shares, ranging from 12 to 20 inches in size, either regular or short, with polished or shot blast surface, fit both frogs.

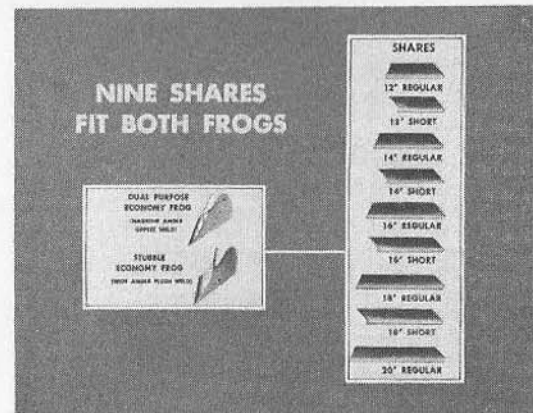

27

SHORT SHARES USED WHEN PENETRATION IS A PROBLEM

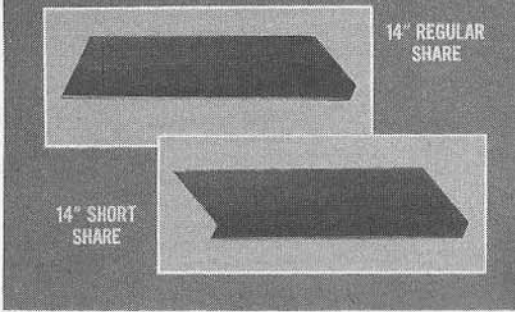

28

SHORT SHARES USED WHEN PENETRATION IS A PROBLEM.

Here we see a 14" regular and a 14" short share.

A short share has 3" less cutting edge to be forced into the ground and therefore penetrates hard ground better than a regular share, just as a spade penetrates the ground easier than a scoop shovel. The short share also reduces draft.

With a short share, a portion of the furrow slice is uncut. This is torn loose by the lifting and turning action of the moldboard.

CHOICE OF SURFACE TYPE IN ALL RAZOR BLADE SHARES

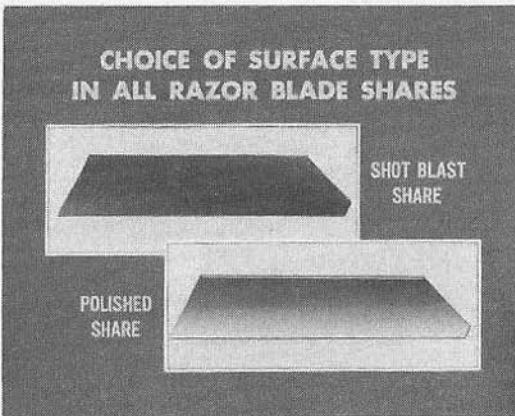

29

There is a CHOICE OF SURFACE TYPE IN ALL RAZOR BLADE SHARES.

- Shot blast
- Polished

Shot blast share is less expensive because the polishing step in manufacturing is eliminated. This type share is adequate for abrasive soil or where scouring is not a problem.

Polished shares should be used under the more difficult scouring conditions.

Now let's get into specific Ford Economy Plow Bottoms. There are 3 Basic Economy Bottoms. First the . . .

SOD AND CLAY BOTTOM

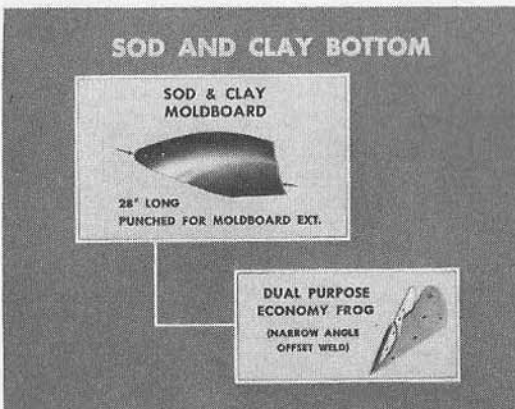

30

SOD AND CLAY BOTTOM

This bottom uses the Sod and Clay Moldboard and the Dual Purpose Frog.

- The moldboard is about 28" long
- It is punched for moldboard extension
- It comes in one size only

GENERAL PURPOSE BOTTOM AND STUBBLE BOTTOM

The four different size moldboards you see here are used with the Dual Purpose Frog to make up General Purpose Bottoms, and with the Stubble Frog to make up Stubble Bottoms.

You can easily determine moldboard size by remembering that the 14" size is 28" long. If the board is less than 28" long it is a 12 inch size. If above 28" in length, both the size and length increase is in 2 inch increments.

12" size—25" length

14" size—28" length

16" size—30" length

18" size—32" length

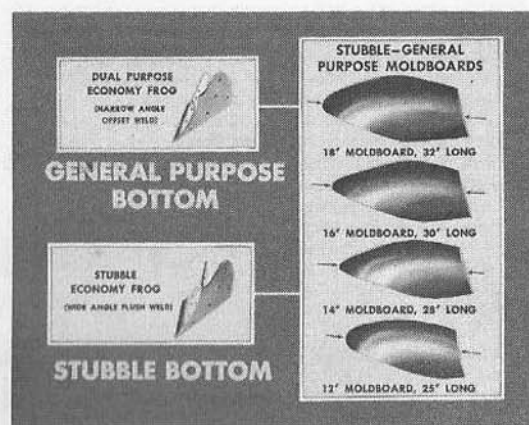

31

Now let's consider the IDENTIFICATION OF ECONOMY MOLDBOARDS. Economy moldboards are easily identified. Any Economy moldboard with provision for attaching a moldboard extension is the Sod and Clay Board.

Any Economy moldboard without provision for an extension is a Stubble-General Purpose Board, and can be easily identified for size by measuring the length.

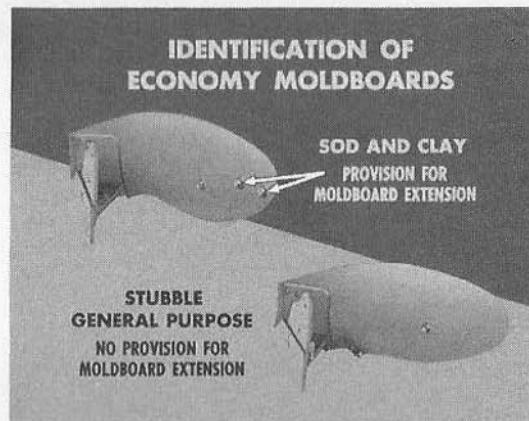

32

SHIN AND LANDSIDES

- Only one way to use them.
- Do the same job on all bottoms.
- Are not varied to influence performance or to change the type of bottom.

SHARES

- Variations change bottom performance, do not change bottom type.

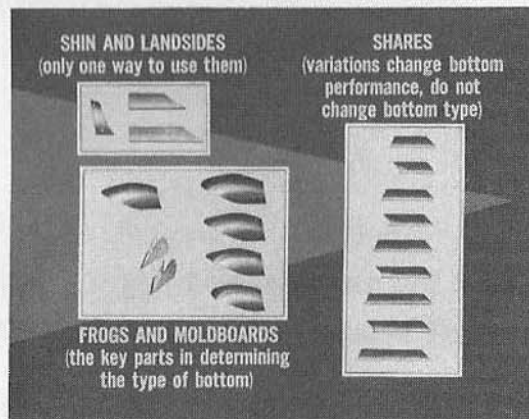

33

The type of share—polished vs. shot blast, regular vs. short—may have a great influence on performance, but they do not in any way determine the type of bottom.

FROGS AND MOLDBOARDS

- The key parts in determining the type of bottom.

The two frogs and 5 moldboards provide the variations which determine the type of Economy bottom, Sod and Clay, Stubble or General Purpose.

FORD ECONOMY PLOW BOTTOMS

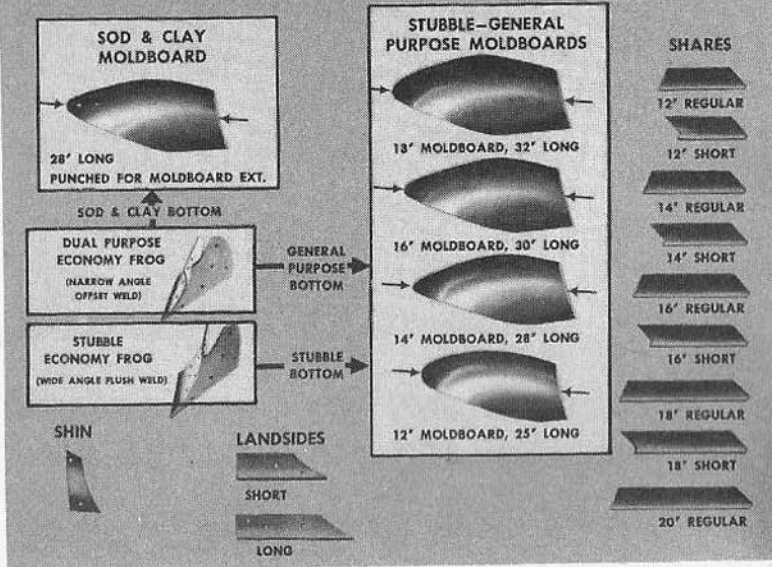

34

Now let's cover the performance advantages of the Ford line of Economy Plow Bottoms.

These parts are used in making up the three basic types of FORD ECONOMY PLOW BOTTOMS.

- Sod and Clay
- General Purpose
- Stubble

Note to leader: Review combinations of moldboards and frogs that make up the three types of Economy Bottoms.

SOD AND CLAY ECONOMY BOTTOM

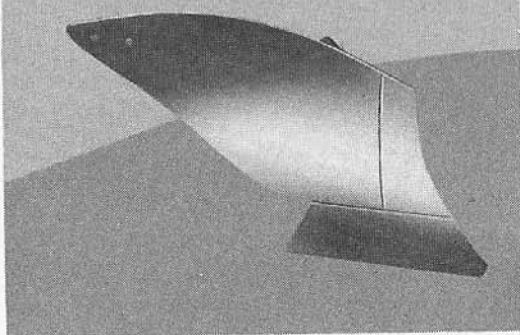

35

SOD AND CLAY ECONOMY BOTTOM

- Sod and Clay Moldboard on Dual Purpose Frog
- Performance
 - gentle turn moldboard
 - lower pressure moldboard
 - high or low speed
 - good penetration

Use of the narrow angled frog means this bottom penetrates better and sets up less pressure between moldboard and furrow slice.

The Sod and Clay Moldboard has a long, gentle turn which inverts the furrow slice slower, more completely, and with less pulverizing. The slice tends to be turned completely over in an unbroken ribbon.

This bottom can be used at higher speeds (up to 5 m.p.h.) without excessive "throwing" of the furrow slice. Definite crowning of the furrow can be accomplished with the Sod and Clay Economy Bottom by using lower speeds.

A moldboard extension may be attached for better handling of the furrow slice ribbon.

STUBBLE ECONOMY BOTTOM GIVES:

- Higher moldboard pressure, low speed
- Good scouring
- Good trash coverage
- Good pulverization

It is the only bottom which uses the wider angle Stubble Frog, which results in greater pressure between moldboard and furrow slice, thus reducing scouring problems in wet and sticky soils.

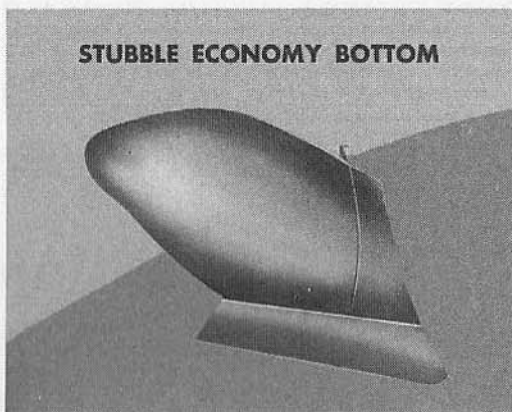

36

The Stubble Bottom turns the furrow slice quickly and abruptly, pulverizes the soil and covers trash well.

THE GENERAL PURPOSE ECONOMY BOTTOM

- Uses the dual purpose frog
- Has lower moldboard pressure, higher speed
- Gives good penetration
- Gives versatility

Since the General Purpose Bottom uses the narrow angled frog, it can be used at relatively higher speeds without excessive throwing of the furrow slice.

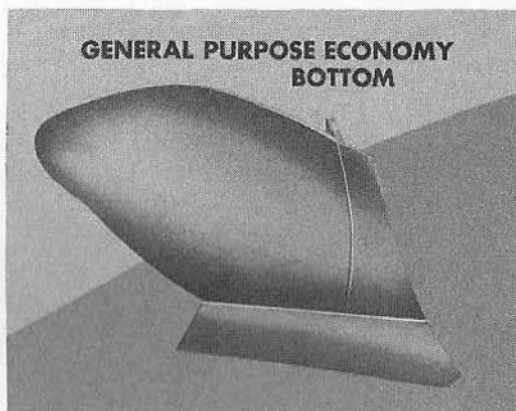

37

Use of the narrow angle frog also means that this bottom will go into the ground easier than the Stubble Bottom when penetration is a problem.

In performance, the General Purpose Bottom falls between the Sod and Clay bottom and the Stubble Bottom. While it is not a specialized bottom it will work well in a wide variety of conditions.

Where scouring and excessive trash is not a problem, the higher speed of the General Purpose Bottom is a distinct advantage over the Stubble bottom.

In abrasive soils, the lower moldboard pressure of the General Purpose Bottom means longer moldboard life.

Basic Economy Plows, with share and moldboard matching frame size, meet most plowing conditions.

- 12- and 14-inch Sod and Clay Plows
- 12-, 14-, 16- and 18-inch Stubble Plows
- 12-, 14-, 16- and 18-inch General Purpose Plows

38

These basic Economy Plows will handle a great many plowing needs. It is very important to know which one to recommend to meet specific conditions. Likewise, the ability to quickly identify a plow is a vital factor in trouble shooting. Any person who knows how these plows are made up, and who thoroughly understands the performance characteristics of each, is well along in understanding the entire Ford Economy Plow line.

BASIC ECONOMY PLOWS, WITH SHARE AND MOLDBOARD MATCHING FRAME SIZE, MEET MOST PLOWING CONDITIONS

- 12 and 14-inch Sod and Clay Plows
- 12, 14, 16 and 18-inch Stubble Plows
- 12, 14, 16 and 18-inch General Purpose Plows

PLOW FRAME DETERMINES WIDTH OF CUT

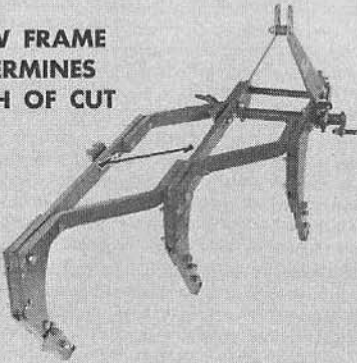

39

Now in analyzing the operation of a moldboard plow, it is very important to keep in mind that it is the PLOW FRAME ALONE WHICH DETERMINES THE WIDTH OF CUT.

BASIC 14-INCH PLOW

14-INCH FRAME

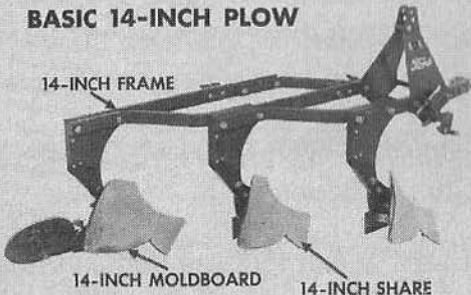

14-INCH MOLDBOARD

14-INCH SHARE

40

The moldboard and share are usually the same size as the frame. For example: A BASIC 14" PLOW as we see here, is made up of a 14" frame, a 14" moldboard and a regular 14" share.

ECONOMY PLOWS WITH COMBINATIONS OF FRAME, MOLDBOARD AND SHARE SIZE, ARE AVAILABLE TO MEET SPECIAL CONDITIONS.

- Reduced size moldboards—for scouring problems
- Long shares—for root cutting problems
- Short shares—for penetration problems.

Economy Plows, with combinations of frame, moldboard and share size, to meet special conditions.

- Reduced size Moldboards—for scouring problems
- Long Shares—for root cutting problems
- Short Shares—for penetration problems

41

Economy Bottoms provide a high degree of versatility in making up plows. In addition to the basic Economy Plows, it is possible to provide combinations of frame, moldboard and share size which will aid in dealing with special conditions. The three most commonly used combinations are:

- Reduced size moldboards—for scouring problems.
- Long shares—for better cutting of roots, as in plowing under alfalfa.
- Short shares—for penetration problems.

PLOWS WITH REDUCED SIZE MOLDBOARD can be had with bottoms in the three sizes shown here: 16 x 14, 16 x 12, 14 x 12. The numbers designate frame and moldboard sizes. Since share size is usually the same as frame size, a 16 x 12 plow has a 16 inch frame and shares, and a 12 inch moldboard.

REDUCED SIZE
MOLDBOARD PLOWS

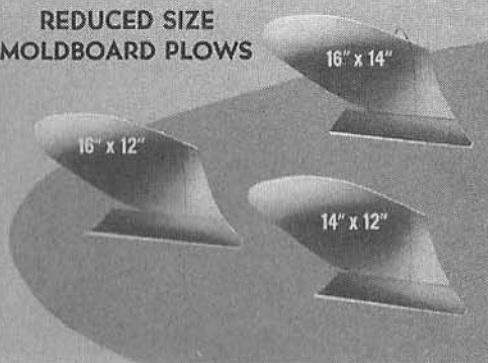

42

In summarizing, remember that with FORD ECONOMY PLOWS, there are many combinations of frame sizes, moldboard and share sizes, and frog and moldboard types to meet a wide variety of plowing conditions. Next, let's look at . . .

FORD ECONOMY PLOWS

Many combinations of frame sizes, moldboard and share sizes, and frog and moldboard types to meet a wide variety of plowing conditions.

43

FORD PLOW ACCESSORIES

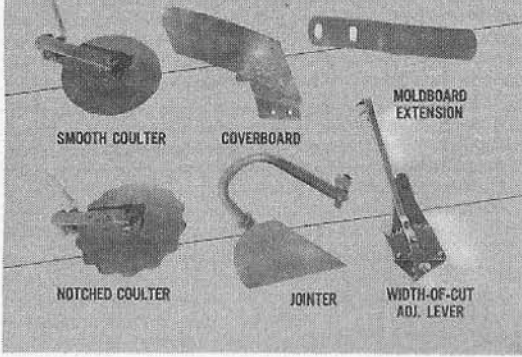

44

FORD PLOW ACCESSORIES

- Smooth coultter
- Coverboard
- Moldboard extension
- Notched coultter
- Jointer
- Width of cut adjusting lever

Let's cover each of these in more detail.

COULTERS SLICE FURROW AHEAD OF MOLDBOARDS

- Cut trash, surface growth, roots
- Aid in clean cut and turn of furrow slice
- Smooth or notched types available

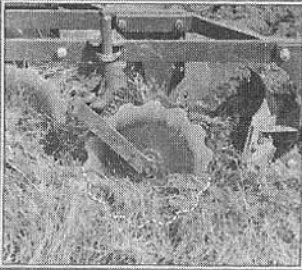

45

COULTERS SLICE FURROW AHEAD OF MOLDBOARDS

- Cut trash, surface growth, roots
- Aid in clean cut and turn of furrow slice
- Smooth or notched types available

The notched rolling coultter is designed to hold and cut corn stalks or heavy stubble where the smooth coultter might push loose trash ahead and clog.

COVERBOARDS

- Help turn under heavy trash
- Reduce trash collection on plow frame
- Especially helpful in anchored trash



46

COVERBOARDS

- Help turn under heavy trash
- Reduce trash collection on plow frame
- Especially helpful in anchored trash



47

Note the much better coverage of trash by the bottoms equipped with a coverboard. Coverboards perform well in stony soil which may make use of jointers difficult. They are particularly effective in handling anchored trash and for deep plowing as shown with this 4 bottom plow.

JOINTER SLICES AND TURNS STRIP OF SOIL AT SIDE OF FURROW SLICE FOR BETTER TRASH COVERAGE.

The jointer performs much like a plow bottom, except in miniature. It cuts a small strip off the side of the main furrow slice and throws it onto the main furrow slice. In this way it holds down surface trash and partially covers standing stubble, which is then turned with the main furrow slice and buried in the bottom of the furrow.

The jointer is particularly effective in plowing sod.



JOINTER SLICES AND TURNS STRIP OF SOIL AT THE SIDE OF FURROW SLICE FOR BETTER TRASH COVERAGE

48

THE MOLDBOARD EXTENSION USED FOR BETTER TURNING OF THE FURROW SLICE. It gives the furrow slice additional roll as it leaves the moldboard. It is very helpful for turning the furrow slice in sod.



MOLDBOARD EXTENSION FOR BETTER TURNING OF FURROW SLICE

49

WIDTH OF CUT IS EASILY SET WITH THE WIDTH OF CUT ADJUSTING LEVER.

It allows quick change when needed for hillside work and contours.

Now, let's consider how to easily identify plow sizes and types.

WIDTH OF CUT EASILY SET WITH LEVER

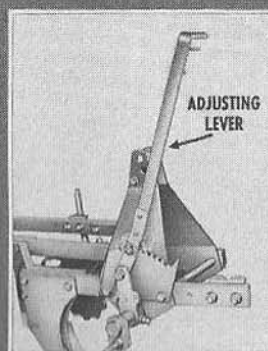

50

QUICK IDENTIFICATION OF A PLOW FOR SIZE AND TYPE IS VERY IMPORTANT. Anyone dealing with Ford plows should be able to walk up to one and very quickly identify the basic components that determine plow performance.

These are: Size of frame, type of frog, type and size of moldboard, and size of share.

QUICK IDENTIFICATION OF A PLOW FOR SIZE AND TYPE IS VERY IMPORTANT

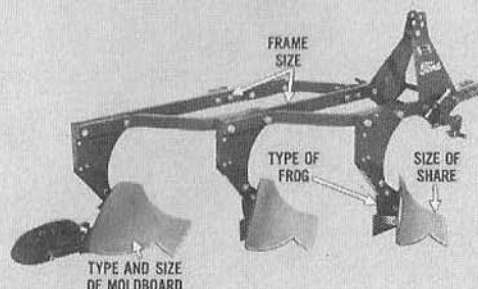

51

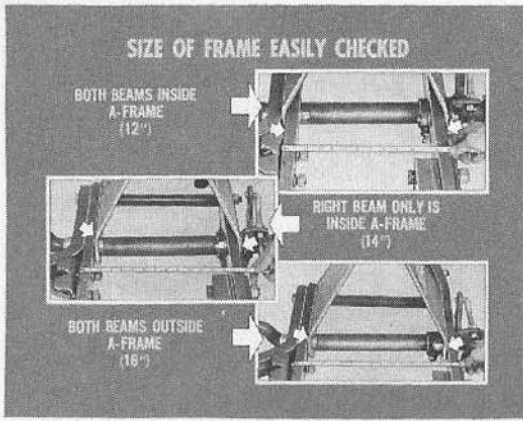

52

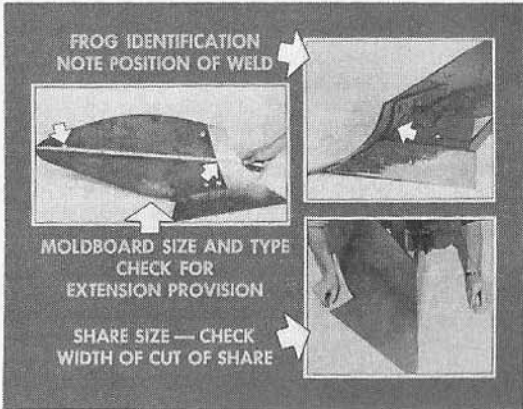

53

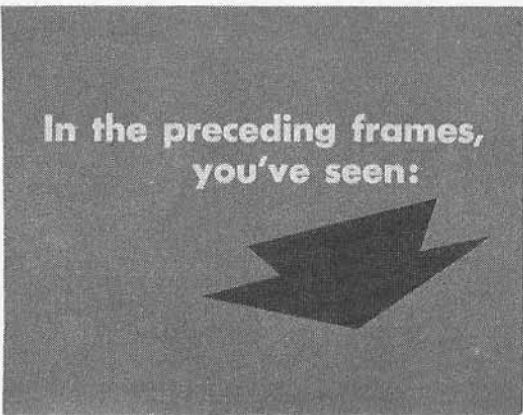

54

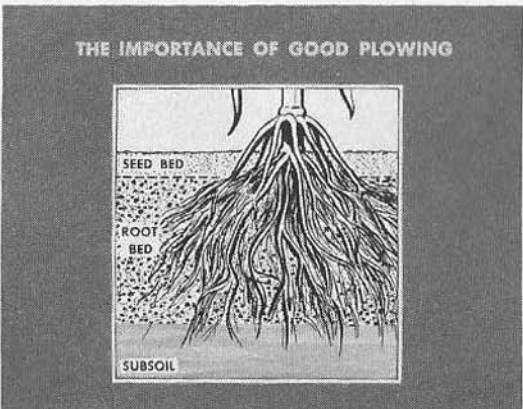

55

SIZE OF FRAME EASILY CHECKED on Ford high clearance plows by measuring across beams or noting position of beams in relation to A-frames.

- Both beams inside A-frames—12" frame
- Right beam only inside A-frame—14" frame
- Both beams outside A-frame—16" frame

Parts of Economy Bottoms are easily identified.

- Frog identification is made by noting the position of the weld; flush or offset.
- Check moldboard for size by measuring and for type by whether or not there is provision for moldboard extensions.
- Identify share size by checking width of cut of share.

In the preceding frames you've seen . . .

THE IMPORTANCE OF GOOD PLOWING with respect to good seed and root bed preparation.

THE BASIC FORD MOLDBOARD PLOW FRAMES for the FMD tractor and Ford tractor.

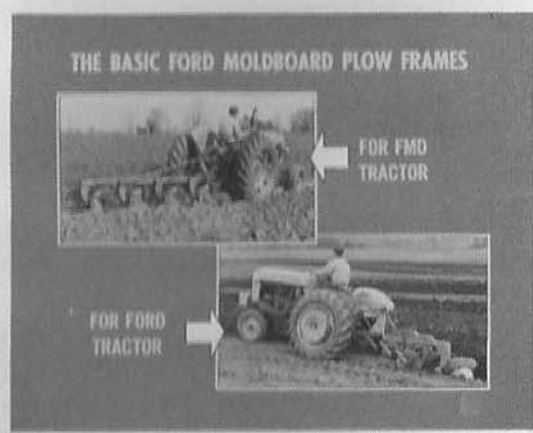

56

THE FORD LINE OF STANDARD BOT-TOMS which include the Stubble, General Purpose, Sod and Clay and Scotch Bottoms.

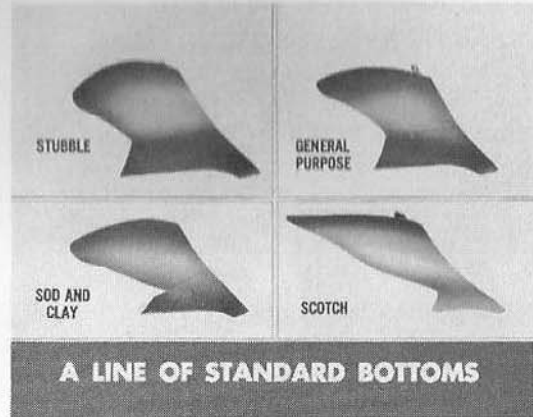

57

A LINE OF ECONOMY BOTTOMS which include the Sod and Clay, Stubble and General Purpose Bottoms.

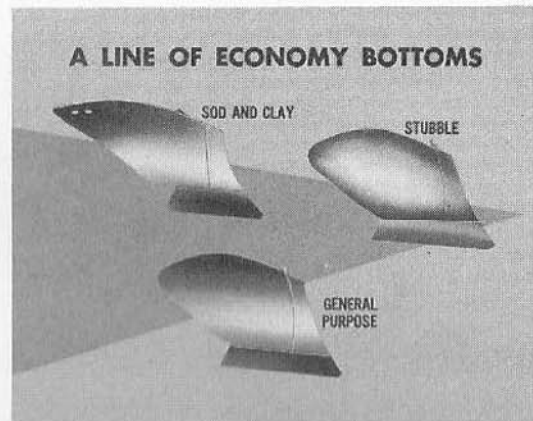

58

FORD ECONOMY PLOW BOTTOMS with respect to their parts and the interchangeability of those parts to help meet plowing problems and conditions.

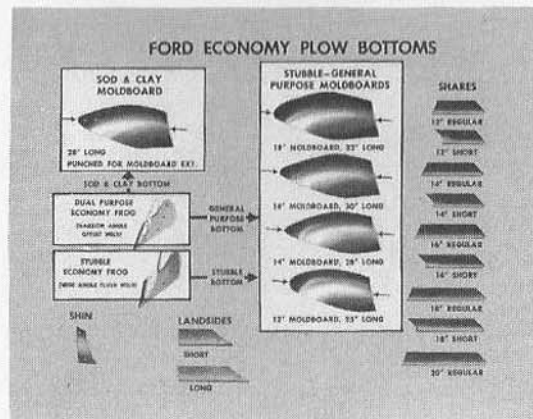

59

FORD PLOW ACCESSORIES

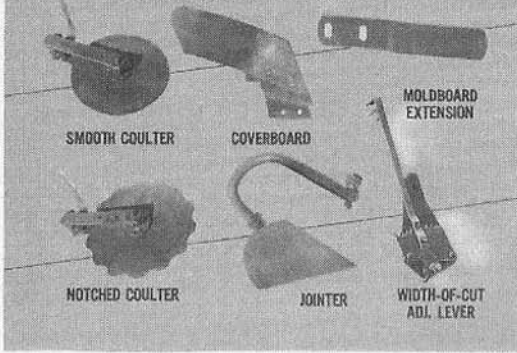

A LINE OF FORD PLOW ACCESSORIES

60

HOW TO IDENTIFY FORD PLOWS

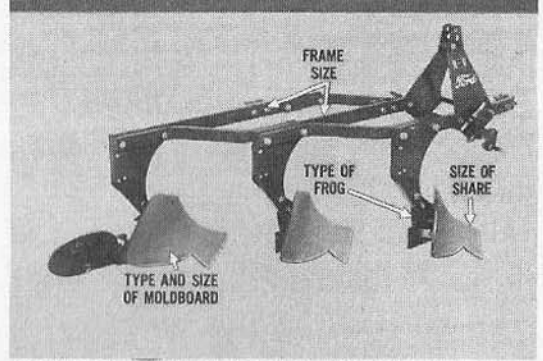

HOW TO IDENTIFY FORD PLOWS by determining frame sizes, moldboard size and type, type of frog, and size of share.

64

Know these basic elements
in the Ford plow line!

Know how to operate and adjust
the plows they make up!

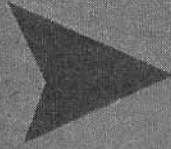

Then you can, more
effectively, sell and
service this excellent line
of Ford Moldboard plows:

61

Know these basic elements in the Ford Plow Line! Know how to operate and adjust the plows they make up! Then, you can more effectively sell and service this excellent line of Ford Moldboard Plows:

FORD PLOWS FOR FORD AND FORDSON MAJOR DIESEL TRACTORS

1- 2- 3- and
4-bottom plows



Choose from wide
selection of
Economy Bottoms
and Standard Bottoms

62

FORD PLOWS FOR FORD AND FORDSON MAJOR DIESEL TRACTORS.

- 1, 2, 3, and 4 bottom plows
- Choose from wide selection of Economy Bottoms and Standard Bottoms.

And gentlemen, all the plow frames and bottoms we've just reviewed are available as order options.

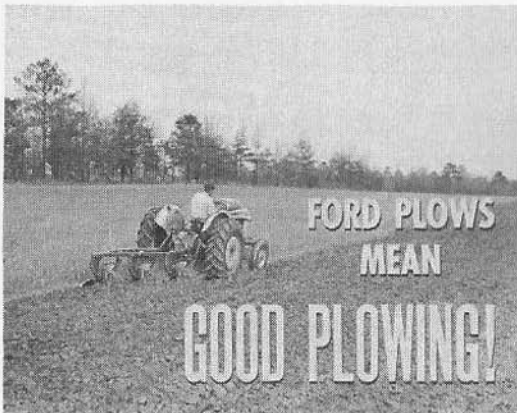

FORD PLOWS MEAN GOOD PLOWING!

SUGGESTED REVIEW QUESTIONS FOR "FORD MOLDBOARD PLOWS PART I"

1. What are the key factors in good plowing? Discuss each. (Re: Frame #4)
2. What is the basic difference between a High Clearance Plow for a Ford tractor and an FMD Tractor? (Re: Frame #10)
3. What are the two lines of Ford Plow Bottoms? (Re: Frame #11)
4. What is the basic difference between a Ford Standard and Ford Economy Bottom? (Re: Frame #11)
5. Name the Ford Standard Bottoms. Discuss the operating characteristics of each. (Re: Frames 12 through 16)
6. What are the five basic parts of an Economy Bottom? What are some of the "Economy" features? (Re: Frames 17 and 18)
7. What are the two Economy Frogs and how are they identified? (Re: Frame #21)
8. How do each of the Economy Frogs affect performance of the bottom? (Re: Frame #22)
9. Which Economy Frog makes up the better penetrating bottom? (Re: Frame #24)
10. What is the relative position of the landside on Economy Bottoms made up on the two different economy frogs? (Re: Frame #24)
11. How many of the nine shares will fit the Dual Purpose Economy Frog? (Re: Frame #27)
12. Under what conditions would you recommend the use of short shares? (Re: Frame #28)
13. What are the Razor Blade Share surface types and the suggested application for each? (Re: Frame #29)
14. How many Basic Economy Bottoms are there? (Re: Frames 30 and 31)
15. How many different moldboards are available for the Sod and Clay Bottom? (Re: Frame #30)
16. What is the size and major identifying characteristics of the sod and clay moldboard? (Re: Frame #30)
17. How many different Economy Moldboards are available to make up the General Purpose and Stubble Bottoms? (Re: Frame #31)
18. What is the length of each of the four G. P. Stubble Moldboards, and how can this be remembered easily? (Re: Frame #31)
19. What are the key parts in determining the type of bottom? (Re: Frame #33)
20. What are the performance characteristics of each of the three types of Economy Bottoms? (Re: Frames 35, 36 and 37)
21. What are the frame, moldboard and share sizes on a basic 14" Economy Plow? (Re: Frame #40)
22. What are the various Economy Plow combinations for handling special conditions? Describe their application. (Re: Frame #41)
23. What is the size of the frame, moldboard and share on a 14 x 12 Economy Plow? (Re: Frame #42)
24. What are the functions of each of the six plow accessories? (Re: Frames 44 through 50)
25. Why is plow identification important? (Re: Frame #51)
26. How would you identify a Ford High Clearance plow frame for size without a measuring device? (Re: Frame #52)
27. List the things to be checked to identify a Ford High Clearance Economy Plow. (Re: Frame #53)

To Meeting Leader: At this point, the group should be asked to identify at least the following three plows, "in the flesh."

1. 14 inch (or 14 x 12) Ford Economy General Purpose Plow.
2. 16 inch FMD Economy Stubble Plow.
3. 14 inch Ford Sod and Clay Economy Plow.